

## **Application of the Green Building Concept (BGH) in High-Rise Office Buildings Based on Hybrid Dynamics to Improve Cost Performance**

**Ahmad Barri**

Master's Program Civil Engineering Study Program. Faculty of Engineering. Mercu Buana University, Jakarta, INDONESIA

E-mail: [ahmadbarri0231@gmail.com](mailto:ahmadbarri0231@gmail.com)

---

| Submitted: January 16, 2024 | Revised: May 20, 2024 | Accepted: May 24, 2024 |

| Published: September 22, 2024 |

---

### **ABSTRACT**

This research aims to determine the application of the green building concept (BGH) in multi-story office buildings based on hybrid dynamics to improve cost performance. The method used in this research is a quantitative method with primary and secondary data types. The sampling technique used purposive sampling with 163 individuals involved in the Ginza Business Loft Jababeka area. The data management and analysis techniques used are outer model analysis (measurement model) and inner model analysis (structural model) using the SmartPLS 3 Multivariate Structural Equation Model (SEM) technique. Partially, the results of this research show that X2.2.21 has a P-Values value of 0.000 for X2.2 has a P-Values value of 0.000 on 0.000, it can be concluded that X3.2.2 has a strong influence on variable X3.2 in the model. The variable X2.3.6 also has a P-value value of 0.000, meaning that X2.3.6 has a significant effect on variable X2. Variable X3.1.6 has a P-value of 0.000 for variable X3, indicating that the auditor quality variable has a significant effect on variable X3. Furthermore, variable Y2.2 has a P-value value of 0.000, indicating that this variable has a significant influence on variable Y2. These results illustrate that variable Y2.2 has a strong influence on variable Y2 in the context of the research model. Overall, the results of the P-Values analysis show that the variables mentioned above have a significant influence on the variables measured.

**Keywords:** offices; green buildings; hybrid systems on cost performance.

### **INTRODUCTION**

Climate change is a major threat to life and global development, one of the triggers of which is Green House Gas (GHG) emissions. For this reason, as well as in order to maintain the momentum of economic growth, Indonesia is carrying out a green economic transition that prioritizes low-carbon development that is inclusive and fair. To smooth this transition, Indonesia has committed to reducing GHG emissions by 2030 by 29% under business as usual conditions and if collaborating with the international community this can be increased to 41%. Furthermore, to achieve this commitment, the Government has planned and begun implementing several strategic steps in several important climate change sectors, namely the Forestry and Other sectors. Land Use (FOLU), energy, agriculture, waste processing, and Use of Industrial Processes and Products (IPPU). Currently, the greatest efforts made by the Government are in the forestry and land use sector, known as Forestry and Other Land Use and the energy sector. The second sector is the largest contributor to GHG emissions in Indonesia currently, with the FOLU sector producing around 60%, and the energy sector producing 36% (Press Release HM.4.6/432/SET.M.EKON.3/11/2021). In Article 1 of Law Number 32 of 2009 concerning Environmental Protection and Management, it is stated that climate change is a change in climate that occurs directly or indirectly due to human activities, causing changes in the composition of the atmosphere globally and changes in natural climate variability observed over time. which can be compared. The 2018 IPCC report states that greenhouse gas emissions are largely driven by increasing global prosperity. Average temperatures will increase by 3-5 °C by the end of this century compared to the pre-industrial era. Maintaining temperature

increases below the 2°C limit will be increasingly difficult if not all parties provide input according to their respective fields. This joint effort also requires various changes, including technological, institutional and behavioral. Efforts to reduce emissions must be carried out in all sectors and all regions. Population growth and increasing prosperity, especially in Asia which is starting to emerge from poverty, have triggered increased energy consumption and use of fossil fuels. In the future, if we do not move quickly to switch to low-carbon technology, projected global emissions will continue to increase and will impact Indonesia. Indonesia is ranked 164th, with an overall score of 28.2. Indonesia's scores for each pillar are ecosystem vitality 34.1, health 25.3 and climate change 23.2. The distribution of scores from the previous assessment period, EPI 2020, fully implemented the principles of environmental conservation, social responsibility and good governance. ESG elements include at least the following elements:

**Environmental factor**

1. Use of environmentally friendly energy;
2. Waste management so that it does not become pollutant;
3. Fair treatment of animals that is not arbitrary; And
4. Implementation of an effective risk management system in managing environmental risks.

**Social factors**

1. Selection of suppliers that also have ESG policies and practices;
2. Organizational involvement in community development in the form of a percentage of profits and/or employee volunteer work for the community;
3. Ensure a healthy and safe work environment for employees;
4. Certainty to consider stakeholder input and expectations of the organization.

**Governance factors**

1. Use of accounting methods that comply with the required standards;
2. Ensure that all relevant parties are given the opportunity to participate in voting to make decisions regarding issues that are important to the country;
3. Ensure that there is no political contribution to obtain preferential treatment from the recipient's contribution;
4. Certainty of not being involved in illegal activities



Figure 1. Sustainable Development Goals Source: SDGs Bappenas

One of the points of the SDGs has a specific focus on climate change (goal no. 13). On the other hand, action to control climate change also plays an important role in the successful implementation of most of the other goals. Of the 17 SDGs goals, there are 12 goals that have climate-related targets, which are related to issues of energy, forestry, food security, education. All of this will support the successful implementation of the Paris Agreement.

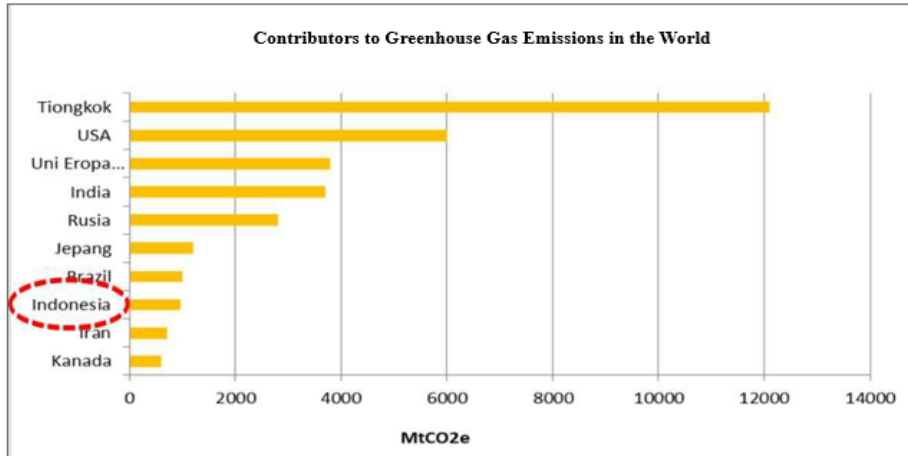

Figure 2. Data on the Largest Contributors to Greenhouse Gas Emissions Source: World Research Institute (WRI)

The World Research Institute (WRI) notes that Indonesia contributes greenhouse gas emissions of 965.3 MtCO<sub>2</sub>e or the equivalent of 2% of world emissions. Indonesia is also one of the world's largest contributors to GHG emissions. From various modeling, Indonesia's GHG emissions are projected to increase by around 2.9 GtCO<sub>2</sub>e in 2030 according to the BAU/business-atypical scenario (without action planning) in the NDC (Nationally Determined Contribution). Without ambitious action, GHG emissions will increase to around 4.3–6.2 GtCO<sub>2</sub>e in 2050. Buildings are estimated to consume more than a third of the world's resources, 12% of the total available clean water, and contribute almost 40% of total emissions.

The building industry sector is the world's second largest natural resource consumption sector after the food industry sector. Building industry players have an important role in reducing environmental impacts due to global warming (Choirunisa et al., 2023). Starting from the construction stage to the operational stage, we cannot avoid the use of increasingly limited natural resources, not to mention other impacts arising from the use of building facilities and the selection of building materials related to increasing temperatures on earth.

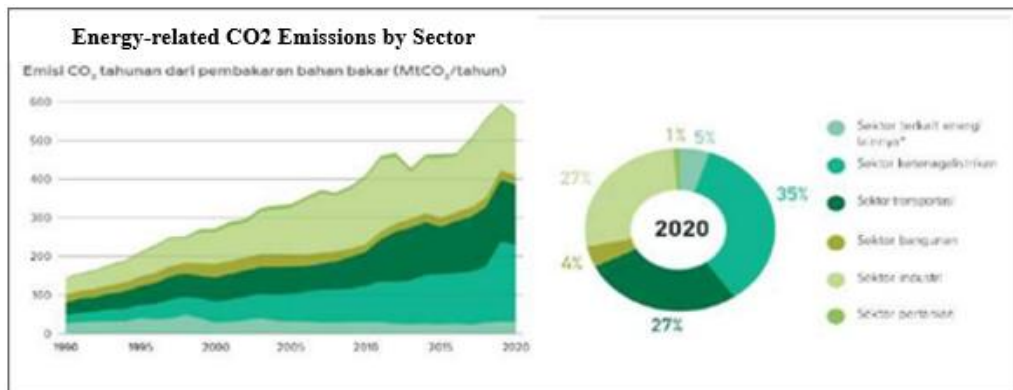

Figure 3. Energy-related CO<sub>2</sub> Contributor Data by sector Source: Climate Transparency Report, 2021

Buildings in Indonesia contribute 3.8% of direct CO<sub>2</sub> emissions and 20.7% of indirect CO<sub>2</sub> emissions. Per capita emissions from the building sector (0.58 tCO<sub>2</sub>/capita) are far below the G20 average (1.46 tCO<sub>2</sub>/capita). Indonesia's policies are not sufficient for the 1.5°C pathway.

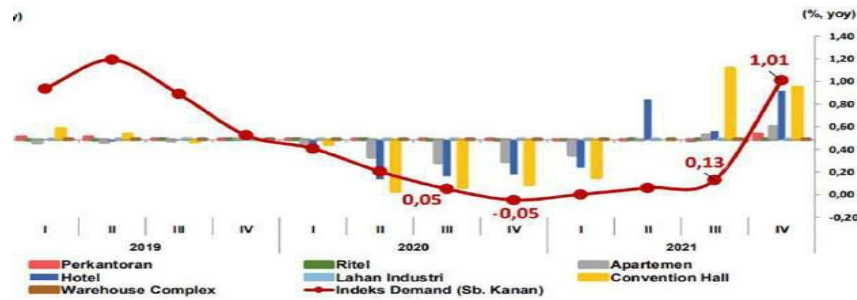

**Figure 4.** Per Capita Emission Data for the Building Sector Source: Climate Transparency Report, 2021

Per capita building-related emissions in 2020 were well below the G20 average. However, the five-year trend is increasing at a rate of 38%, while the G20 average trend is decreasing by 3%. One of the main reasons for the increase in per capita emissions is the high share of fossil fuels in electricity generation.

(Abo-Youssef et al., 2023) further argued that green buildings are designed for economic and environmental sustainability, taking into account the local climate and cultural needs, which can facilitate the health, safety and productivity of the occupants. (Sipil et al., 2023) explain that the green building movement is now mature enough to show evidence of the value of the green economy in the real estate market for building owners and their tenants with the rapid increase in the use of renewable energy, and the conversion of information technology and development technology in the development of smart cities, eco-district, and eco-campus.

In Indonesia, green property is not only in great demand, but has also become a necessity nowadays, especially in tall buildings. This was stated by the Chairman of the Indonesian Real Estate Certification and Advocacy Agency (REI) during the discussion 'Towards a Green Indonesia', Wednesday (27/6/2012). According to him, property developers are encouraged to build buildings with a green building concept (Berita Satu, 2013). This is supported by the regulations created to regulate this, especially through the Minister of Public Development (PU) Regulation of 2014 which has been drafted and Jakarta Governor Regulation No. 38. which already existed. Indonesia itself has set a target to reduce greenhouse gas emissions by 26% by 2020. This is as stated in the Presidential Regulation of the Republic of Indonesia Number 61 of 2011 concerning the National Action Plan for Reducing Greenhouse Gas Emissions (RAN – GRK).



**Figure 5.** Commercial Property Demand Index (CPD) Source: Commercial Property Survey – Bank Indonesia (2021)

The latest Commercial Property Survey conducted by Bank Indonesia revealed a marginal increase in demand for Office property on an annual basis in the fourth quarter of 2021, the Office Demand index in the reporting period recorded growth of 0.55% (yoy), up from 0.51% (yoy) in third quarter of 2021.

The Indonesian Green Building Council or Green Building Council Indonesia (GBC Indonesia) is an independent (non-government) institution that is fully committed to educating the public in applying environmental best practices and facilitating the sustainable transformation of the global building industry. GBC Indonesia aims to carry out market transformation and dissemination to the public and building actors to apply green building principles. Especially in the building construction industry sector in Indonesia. One of GBCI's programs is holding green building certification activities based on a typical Indonesian assessment tool called GREENSHIP. GREENSHIP is an assessment system that is used as a tool to assist industrial, building players, including entrepreneurs, architects, electrical mechanical technicians, interior designers, and other actors in implementing best practices and achieving standards. GREENSHIP has implementation guides for Neighborhoods, Homes, New Buildings, Existing Buildings, and Interior Spaces with different criteria and points (Virginia et al., 2023).

Judging from its benefits to the environment and the health of creatures, so far the majority agree and support the 'green building' concept. The green building concept is related to building design in such a way that the use of several main resources such as energy, water, building materials, land is much more efficient than buildings in general. Building design with a green building concept also creates a healthier, environmentally friendly working atmosphere, optimizes natural lighting and ventilation, and also encourages the creation of clean air and a healthy environment.

Indonesia is ranked 164th, with an overall score of 28.2. Indonesia's scores for each pillar are ecosystem vitality 34.1, health 25.3 and climate change 23.2. Compared to the scores from the previous assessment period, Indonesia's 2020 EPI experienced a decline in all assessment groups. Based on the 2020 EPI, Indonesia's ecosystem vitality score is 43.7, then health is 29, and climate change is 54.4. In total, Indonesia's score was also better, namely 37.8. This score placed Indonesia in 116th place at that time, much better than its current position.

In Indonesia, green property is not only in great demand, but has also become a necessity nowadays, especially in tall buildings. This was stated by the Chairman of the Indonesian Real Estate Certification and Advocacy Agency (REI) during the discussion 'Towards a Green Indonesia', Wednesday (27/6/2012). The latest Commercial Property Survey conducted by Bank Indonesia revealed a marginal increase in commercial property demand on an annual basis in the third quarter of 2021. The Commercial Property Demand Index (CPD) in the reporting period recorded growth of 0.13% (yoy), up from 0.06% (yoy) in the second quarter of 2021 and 0.05% (yoy) in the third quarter of 2020.

There are many aspects that need to be considered in the green building design process. Building environmental aspects must consider the location, design, construction, operation and



maintenance of the building. Then, the construction process and building operational processes will require the consumption of energy, water, materials and natural resources. Green Building is defined as “The practice of creating structures and using processes that are environmentally responsible and resource efficient throughout the entire life cycle of a building from site to design, construction, operations, maintenance, renovation and deconstruction.” This practice expands and complements classical building design concerns of economy, utility, durability, and comfort. Green buildings are also known as “sustainable or 'high performance' buildings”.

One of the important factors in creating a green building is the fulfillment of the basic elements of comfort and health for its users. The average person spends 80% of their time indoors. Buildings that do not pay attention to comfort aspects cause various health impacts called sick building syndrome. Sick Building Syndrome (SBS) is a non-specific feeling of health related to the condition of a building based on complaints from a person or group of people. SBS is caused by air ventilation and pollutants from both inside and outside the building. Building air flow rates in Indonesia have been standardized by National Standards (SNI) in SNI 03-6572-2001, concerning Procedures for Designing Ventilation and Air Conditioning Systems in Buildings.

Indoor health and comfort is one of the categories of Green Building. Physical comfort is associated with five aspects: spatial, thermal, visual or lighting, audio, and smell. The comfort standards set by the Green Building Council Indonesia (GBCI) are a temperature of 25 °C and a relative humidity of 60%. According to Olgyay's Bioclimatic Chart<sup>8</sup> the comfort zone is in the temperature range of 23-29 °C with relative humidity between 18-50%. Humidity of 78% can only be tolerated during low temperature conditions, up to 23°C.

Several sources say that this Green Building concept design generally has the consequence of higher construction costs. The application of green concepts such as the application of energy saving systems, lighting, conservation and water recycling causes an increase in green construction costs (Retrofitting costs) by 10.77% (Ihsan & Risonarta, 2023). If so, we need to see from an economic perspective whether the Green Building concept is more profitable or not. Together we will answer this problem by applying an economic framework using the Hybrid Dynamics concept.

Systems Dynamics is a computer-aided approach to policy analysis and design. This applies to dynamic problems that arise in complex social, managerial, economic, or ecological systems, literally any dynamic system characterized by interdependence, mutual interaction, information feedback, and circular causality (Indonesian Dynamic Systems Expert). The objectives of this research are as follows: (1) to analyze the factors that influence the concept of Green Buildings (BGH) using statistical analysis. (2) analyze the factors that influence the concept of Green Buildings (BGH) using statistical analysis (3) analyze the factors that influence the concept of Green Buildings (BGH) using statistical analysis

### **Construction Projects**

According to (Sirait et al., 2023) a project is a temporary effort to produce a unique product and/or service. A project is a combination of various resources and a series of activities gathered in a temporary organizational container to achieve a certain goal. Projects are one-time activities, with limited time and resources to achieve a predetermined end result, such as a product or production facility

Construction is all activities related to the implementation of building activities. A construction project is an activity whose final result is a building or construction that is integrated with the land on which it is located, whether used as a residence or as a means of other activities. A construction project is a series of interrelated activities to achieve certain goals (building/construction) within certain time, cost and quality limits. Construction projects always require resources, namely man (humans), materials (building materials), machines (equipment), methods (implementation methods), money (money), information (information), and time (time).

The construction industry is an industry that has a wide spectrum of project coverage ranging from simple and low risk to complex and high risk. The construction industry itself can be categorized as a goods industry, although there are several process parts in the construction industry that are included in the service business category. This is because the construction industry at the end of the project produces goods in the form of buildings, both buildings and infrastructure. The large number of parties involved in a construction project means that a project will become more complex the bigger the project. In the construction industry, project definition has traditionally been linked to the construction work process on site. Because pre- and post-construction activities have been put aside and even accelerated in order to quickly reach a new construction or project stage, identification of client needs has become poor and resulted in potential answers being found late to provide input to experts. Any attempt to define or create a 'design and construction process must include the entire project from the creation of requirements to the management of the completed facility and including its demolition. This approach ensures that all issues are considered from both a technical and business perspective. Furthermore, this approach also recognizes and examines the dependencies of each activity over the project time span. This approach also focuses on 'front end' activities, which means it focuses on identifying, defining and evaluating client needs so that the solutions provided are in accordance with these needs. Construction projects are a major part of the construction industry. There are many ways to categorize construction projects, one of which is to categorize them based on the type of construction into four categories. The division into categories for the types of construction projects is:

**Residential construction**

Included in this category are houses, apartments and supporting facilities. Those who build residential construction are divided into two categories, namely those who make buildings according to orders and those who build houses based on standards. This work is usually not auctioned but is based on direct agreement with the client or owner for custom-made buildings.

**Commercial construction**

Included in this category are shops, schools, libraries and all buildings, except houses, that form the built environment. Actors in this industry are the government and the private sector. Procurement of this work depends on the client or owner, for the private sector it varies greatly and for the government it uses the lowest price auction system.

**Industrial construction**

Examples of this category are factories, refineries, gas pipelines, and power plants, including high-tech facilities, namely hospitals and sterile places. The contractor carrying out this work is a specialist contractor and the procurement uses a negotiation system.

**Heavy/Highway construction**

Included in this category are infrastructure facilities such as roads, railway lines, toll roads, tunnels and bridges, which are examples of this project. The client or owner is the government and procurement uses the lowest price auction system.

**Building**

A building is a physical form resulting from construction work that is integrated with its position, partly or wholly above and/or in land and/or water, which functions as a place for humans to carry out their activities, whether for housing or residence, religious activities, business activities, social, cultural and special activities. (PERMENPU Number 6 of 2017). Tall Building is a term to refer to a building that has a tall structure. Some definitions of tall buildings include:

1. Buildings have a characteristic height of more than 22 meters (Kumalasari & Febriansyah, 2023)
2. The Oxford English Dictionary defines a tall building as "a building that has many stories".

3. Tall buildings are buildings that have a height of more than 8 layers (DKI Regional Regulation of 1991)
4. Tall buildings are classified into tall buildings I, height  $\leq 40$  m or 5-8 floors and tall buildings II, height  $\geq 40$  m or  $\geq 9$  floors (Surabaya Regional Regulation No. 7 of 1992)

### **Green Buildings**

A 'green' building is a building that, in its design, construction or operation, reduces or eliminates negative impacts, and can create positive impacts, on our climate and natural environment. Green buildings conserve valuable natural resources and improve our quality of life (World Green Building Council).

There are several things that need to be considered and fulfilled when building a green building, including:

1. Use of water and other resources must be done efficiently.
2. Utilizing renewable energy in buildings, such as installing solar panels and air turbines.
3. Pollution and waste reduction measures. If possible, there needs to be a place to recycle waste.
4. Consider the quality of life of the residents inside.
5. Building designs are designed so that they can adapt to changes in the environment.

### **Green Building Principles**

The following are the principles of green building according to Brenda and (Robert Vale, 1991) in the book Green Architecture Design For Sustainable Future:

#### **Conserving Energy**

The main key to this principle is to utilize energy sources, namely solar energy, as much as possible in the operation of a building.

#### **Working With Climate**

The main key to this principle is utilizing natural conditions, climate and the environment in the form of building operations.

#### **Respect For Site**

The key to this principle is planning which refers to the relationship between the function of the building and the land on which the building is built. This is intended so that the existence of the building, both in terms of construction, shape and operation, does not damage the surrounding environment.

#### **Respect For Users**

The key to this principle is prioritizing the comfort and health of the occupants.

### **Green Building Council Indonesia (GBCI)**

The Indonesian Green Building Council Institute or Green Building Council Indonesia (GBCI) is an independent (non-government) and non-profit (non-for profit) institution that is fully committed to educating the public in applying environmental best practices and facilitating the sustainable transformation of the global building industry. GBCI is an Emerging Member of the World Green Building Council (WGBC) based in Toronto, Canada. WGBC currently has 97 member countries and only has one GBC in each country.

Green buildings are new buildings that are planned and implemented, or buildings that have been built that are operated by paying attention to environmental/ecosystem factors and meeting the performance: wise land use, indoor air quality, water saving, energy saving, material saving, and reducing waste. (Green Building Council Indonesia).

The following will explain green concepts which are studied from various literature and then see their suitability with the green concept referred to in GREENSHIP which was formed by



GBCI (Green Building Council Indonesia). GREENSHIP is used as a reference because it is a green building assessment tool applied in Indonesia, and the research location is located in it so that the characteristics of the green building used can be more in line with the physical conditions in the field. In GREENSHIP there are 6 aspects of Green Building assessment, namely:

**Appropriate Site Development.**

The scope of this category includes access to public facilities, reduction of motorized vehicles, use of bicycles, green plant landscapes, heat island effect, reduction of the volume of rainwater runoff, site management, attention to surrounding buildings or facilities.

**Energy Efficiency and Conservation.**

In this category, all forms of optimizing the efficiency of energy use in buildings, re-commissioning air conditioning equipment, saving energy in lighting and air conditioning systems, recording and monitoring energy use, operating and maintaining AC equipment, using renewable energy and reducing energy emissions, are covered. inside it.

**Water Conservation**

This category includes sub-measurement of water consumption, maintenance and inspection of plumbing systems, efficiency of clean water use, water quality testing, use of recycled water, use of filtration systems to produce drinking water, reduction of water use from deep wells and use of auto-stop faucets.

**Material Resources and Cycles.**

This category includes the use of refrigerants, use of environmentally friendly materials, waste management, waste sorting, B3 waste management and distribution of used goods.

**Indoor Health and Comfort.**

This category includes indoor air quality, environmental regulation of cigarette smoke, CO<sub>2</sub> and CO gas monitoring, indoor air quality measurements, visual comfort measurements, sound level measurements and building comfort surveys.

**Building Environment Management.**

This category includes innovations in improving building quality, the availability of complete building documents, the existence of a team that maintains green building principles and training in the complete operation and maintenance of green building aspects.

GREENSHIP New Building Eligibility, before starting the certification process, the Project must meet the eligibility requirements determined by GBC Indonesia. These eligibility include:

1. Minimum building area of 2500 m<sup>2</sup>;
2. Willingness to sign a letter of agreement that allows all building data to be studied by GBC Indonesia in case studies.
3. Have an Environmental Management Implementation Report (UKL/UPL) approved by BAPEDAL.
4. Have a Certificate of Acceptability to Function (SLF) issued by the Regional Government.

According to (GBCI, 2013), the calculation of the green building rating is based on elements, including: prerequisite rating, regular rating and bonus rating. There are four levels of Greenship ranking determined by GBCI, namely as shown in Table 1.

**Table 1.** Green building rating based on the GBCI greenship rating tool for new buildings

Predicate	Small	
	Point	Percentage %
Platinum	74	73
Gold	58	57
Silver	47	46
Bronze	35	35

Source: GBCI (2013)

The preparation of this Greenship is supported by the World Green Building Council and implemented by the Rating Commission from GBCI, consisting of 6 (six) categories with a total of 10 prerequisite criteria and 41 credit criteria. The six categories of Greenship in question are:

1. Appropriate Land Use (Appropriate Site Development/ ASD).
2. Energy Efficiency and Conservation (EEC).
3. Water Conservation (WAC).
4. Material Resources and Cycle (MRC).
5. Indoor Health and Comfort (IHC).
6. Building Environment Management (BEM).

#### Green Building Performance Assessment

(Nurman, 2021) The assessment of green building performance used in this book is using a point system. Every green building requirement that can be fulfilled by a building will be converted into a predetermined number of points. The more requirements that can be met, the more points are awarded. Based on the number of points obtained, green buildings are then grouped into three categories: primary, intermediate, and primary.

The assessment of green building performance is presented below. Assessment to obtain a BGH certificate at the planning stage, for certificate:

1. Main, with fulfillment of more than 85% to 100% of the total value.
2. Intermediate, with fulfillment of more than 75% up to 85% of total value.
3. Primary, with fulfillment of 70% up to 75% of the total value. 2

Assessment at the construction implementation stage with a value ratio between the Functional Eligibility Certificate (SLF) and Implementation is 10:90 (ten to ninety). Green building assessment at the implementation stage is carried out to obtain a plaque:

1. Main, with fulfillment of more than 80% to 100% of the total value.
2. Intermediate, with fulfillment of more than 65% up to 80% of total value.
3. Primary, with the fulfillment of 45% to 45%. 65% of the total value.

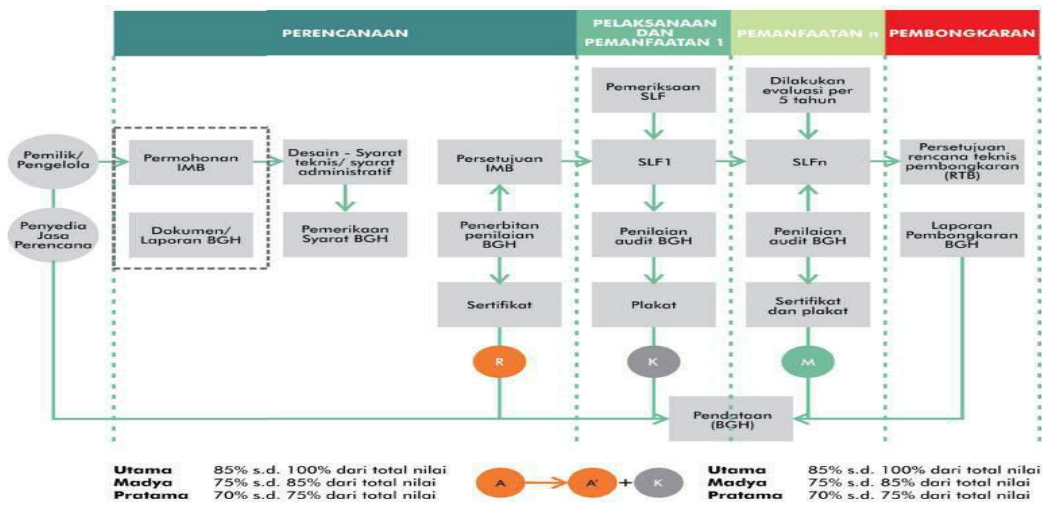

Figure 6. Stages of Green Building Assessment Source: Green Building Rating System, PUPR (2020)

### SEM - PLS Statistical Analysis of Green Buildings (BGH)

The green concept involves an organized construction process that takes into account its impact on the environment throughout the entire life cycle of the building. This includes the design, construction, operation, maintenance and deconstruction stages. According to Minister of Works and Public Housing Regulation no. 21 of 2021, Green Buildings (BGH) refer to buildings that comply with Building Technical Standards and significantly implement measurable and structured performance to save energy, water and other resources at every stage of implementation.

According to (Kurniawan & Husin, 2023) applying Green Construction principles to a project provides added value for contractors by increasing efficiency in the use of electrical energy, water, materials and fuel. Apart from that, this also has the potential to reduce production costs in the construction process and bring greater profits to construction business actors. Efforts to reduce the increase in costs that may occur as a result of implementing the green concept can be done through the application of Value Engineering Techniques in the implementation stage.

Through research on the relationship between the factors that influence the Main Building of the Flour Mill Plant, aspects such as the Green concept, Value Engineering, and Life Cycle Cost Analysis can be investigated in the context of improving the sustainable cost performance of the building. These complex conceptual models and relationships can be tested using the Partial Least Squares analysis model for Structural Equations (SEM-PLS). SEM models include both structural and measurement aspects, and can also be used to fit multilevel models simultaneously, which may not be able to be addressed using linear regression equations alone. SEM is considered a combination of regression analysis and factor analysis, allowing a more holistic approach in understanding the influence of various factors on cost performance.

Partial Least Squares Structural Equation Modeling (SEM-PLS) is a statistical method used to solve multilevel models simultaneously, a task that cannot be overcome using linear regression equations alone. SEM can also be considered as an approach that combines elements of regression analysis and factor analysis. The SEM method is able to handle equation models with more than one dependent variable as well as recursive effects. The SEM approach is based on covariance analysis, so it provides a more accurate covariance matrix when compared to linear regression analysis. Most real-world systems are too complex to be solved by analytical methods alone. Then a simulation is carried out to solve a solution. Simulation is a

computer program that functions to imitate the behavior of certain real systems. Figure 7 provides an overview of how to study the system.

### System Modeling and Simulation

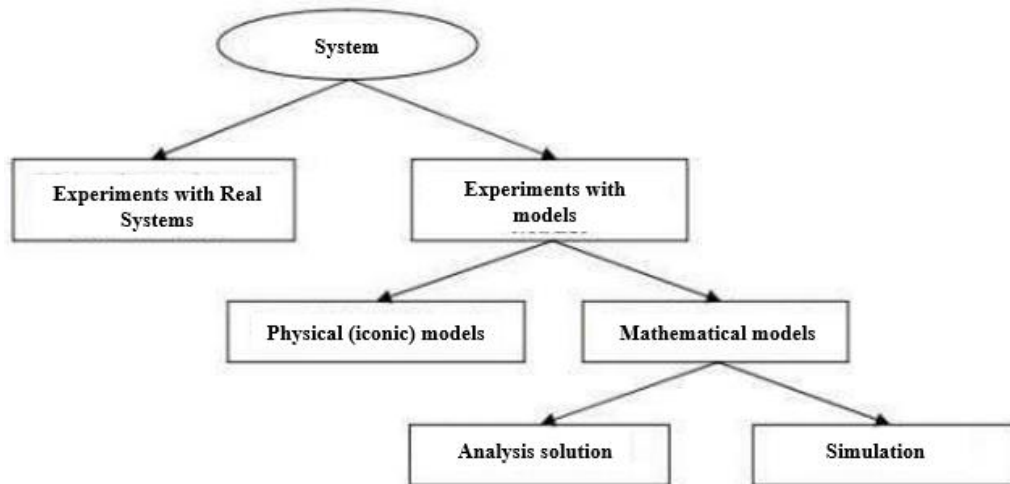

**Figure 7.** System Classification Source: Ekoanindiyo, Firman Ardiansyah (2011)

### Simulation Model

There are 3 dimensions of the simulation model, namely (W. D. Kelton and R. P. Sadowski. *Simulating*, 1998):

1. Continuous and discrete  
The discrete model is where the system status changes at a certain point in time, while the continuous model is where changes in system variables occur continuously over time.
2. Deterministic and stochastic  
The deterministic model does not contain random variables, while the stochastic model contains several random inputs. Models can have deterministic and random variables in different components.
3. Statistics and dynamics  
Model statistics are not affected by changes in time, model dynamics are affected by changes in time.

### Dynamic Systems Simulation

Dynamic system simulation is a continuous simulation developed by Jay Forrester (MIT) in the 1960s, focusing on the structure and behavior of systems consisting of interactions between variables and feedback loops. Relationships and interactions between variables are expressed in a causal diagram. Characteristics of dynamic system models include:

1. Complex system dynamics
2. Changes in system behavior over time
3. There is a closed feedback system
4. This feedback describes new information about the state of the system, which will then result in further decisions

Dynamic systems are a much better method when compared to other conventional methods, where other methods have several weaknesses such as the absence of discontinuity aspects from the external environment, cause and effect relationships between different parameters are not always correct and can even give rise to false relationships between variable. In addition, conventional methods that rely on historical data will not be able to accurately predict major changes.

In contrast to conventional systems, dynamic systems have a contribution to simulation. Some of the advantages of using dynamic systems are:

1. Availability of a framework for aspects of causality, nonlinearity, dynamics and endogenous behavior of the system
2. Create experimental experiences for policy makers based on the behavior of system supporting factors
3. It is easy to set up simulation scenarios according to your wishes
4. Availability of information sources of a mental, written or numerical nature so that the resulting model is more complete and representative.
5. Generate model structures from managerial inputs by simulating them through quantitative computational procedures.

System dynamics is a methodology for understanding a complex problem. This methodology focuses on policies and how these policies determine the behavior of problems that can be modeled by dynamic systems. Figure 8 below shows the development stages with a dynamic system model:

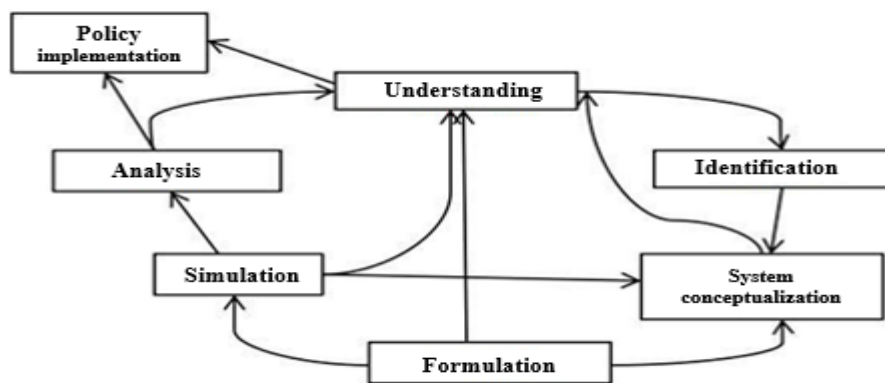

**Figure 8.** Dynamic System Model Development Stage Source: Agung Firdamansyah. ITB (2011)

### Causal Loop Diagrams

According to (Crielaard et al., 2022) Causal loop diagrams provide a language for articulating an understanding of dynamics, the interconnected nature of the world. You can think of it as a sentence constructed by linking key variables together and showing causal relationships between variables. By stringing together several scenarios you can create a coherent story about a particular problem or issue.

The Causal Loop Diagram (CLD) model uses an approach to problem solving by looking at the complexity of the system which is depicted with a diagram in the form of a curved line with an arrow that connects one factor to another. For each arrow in the Causal Loop Diagram.

(CLD) has (+) and (-) signs. This sign shows the relationship between one factor and other factors. The (+) sign indicates a mutually reinforcing relationship, namely that if the factor that is the cause or influencing factor increases, then the resulting factor or factor that is influenced will also increase.

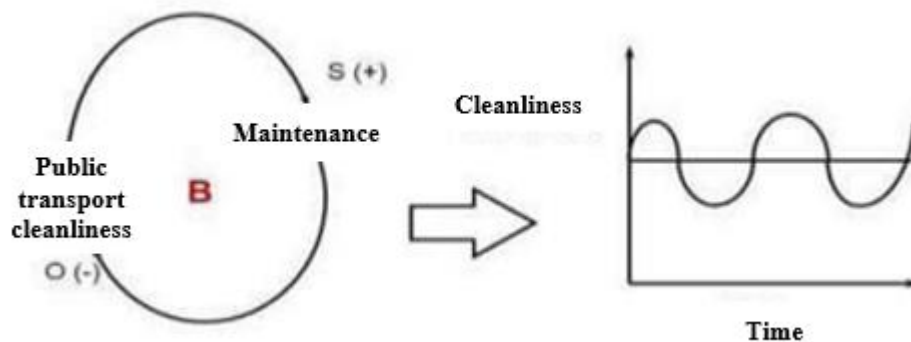

**Figure 9.** Example of Casual Loop Diagram Source: Agung Firdamansyah. ITB (2011)

Figure 9 above shows that maintaining the cleanliness of public transportation must always be carried out. Because the maintenance process is a continuous process and cannot be done just once. When maintenance has been carried out, cleanliness will increase, but as time goes by, cleanliness will decrease again and the maintenance process must be carried out again so that the cleanliness of public transportation is maintained.

Adapted from Sherwood in 2002, there are several things to pay attention to when making a Causal Loop Diagram (CLD), namely:

1. Know the limitations of the problem;
2. Start with something interesting;
3. Know the factors that cause and the factors that cause;
4. Use nouns instead of verbs;
5. Don't use the words increase or decrease;
6. Don't hesitate to include unusual words;
7. Use the signs (+) and (-) for each relationship;
8. A good diagram is a diagram that describes the actual situation;
9. Enjoy creating diagrams;
10. No diagram is completely finished.

### Stock Flow Diagrams

(Baez et al., 2023) Stock (Level) and Flow (Rate) are used to represent activity in a feedback loop. This diagram uses two types of variables called stock (level) and flow (rate). Level states the condition of the system at any time. In engineering, the system level is better known as a state variable system. Level is an accumulation in the system. The equation of a variable rate is a policy structure that explains why and how a decision is made based on the information available in the system. Rate is the only variable in the model that can influence level.

This stock and flow diagram or flow diagram is a more detailed explanation of the previous system shown by the causal loop diagram because this diagram pays attention to the influence of time on the relationship between variables, so that later each variable is able to show the accumulated results for the level variable, and the variable that is The rate of system activity per time period is called the rate.

### Verification and Validation

1. Verification is a process of determining whether the simulation model reflects the conceptual model correctly or not. According to Law and Kelton (1991) Verification is checking the conceptual simulation model (flow diagram and assumptions) into the programming language correctly.
2. Validation; Verification of the model is carried out to find out whether there are no errors in the model. Meanwhile, validation is carried out to find out whether the model matches the real system.



In this final assignment, the method that will be used to carry out validation is through a behavior validity test, which is a function used to check whether the model being built is capable of producing acceptable output behavior.

There are two ways of testing in behavior validation, namely as follows:

- Comparison of averages (mean comparison)

$$E1 = \frac{|\bar{S} - \bar{A}|}{\bar{A}}$$

Information:

S = Average value of simulation results. A = Average value of data

The model is considered valid if  $E1 \leq 5\%$

- Comparison of amplitude variations (% error variance)

$$E2 = \frac{|Ss - Sa|}{Sa}$$

Information:

Ss = Standard deviation of the model

Sa = Standard deviation of data

The model is considered valid if  $E2 \leq 30\%$

### **Discrete Event Simulation (DES)**

Discrete Event Simulation (DES) is a method of modeling a system by evaluating a series of activities as they occur, or by evaluation at specific points in time (every second, for example) with no changes assumed to have occurred between those times. Step. This type of simulation is well suited for activity-based operational modeling where the complexity of continuous simulation is not required.

DES is typically used to understand and improve the performance of a system, in the research and development or design phase, or for processes that are already operational.

Discrete-Event Simulation is a simulation where changes in status occur at discrete points in time that are triggered by events. Common events in these simulations are the arrival of an entity to a workstation, resource failure, completion of an entity

activity, and there is the end of a shift.

This type of event consists of a scheduled event: an event where the time of occurrence can be determined and scheduled in advance and a conditional event which is triggered by conditions encountered, and not by a single time path.

The way to prepare the simulation (setting up the simulation) is as follows:

Simulation time (clock):

1.  $t_i$ : simulation time value (simulation clock) at step  $i$ , for  $i=0$  to the number of discrete events
2. Assume the simulation starts at time zero,  $t_0 = 0$
3.  $t_1$ : simulation clock value when the first discrete event in the list is processed
4.  $t_2$ : simulation clock value when the second discrete event in the list is processed

Entity attributes:

Entity attributes are characteristics of an entity that are retained by the entity until the entity leaves the system. Example for ATM simulation: Arrival Time attribute.

Entity attributes:

Entity attributes are characteristics of an entity that are retained by the entity until the entity leaves the system. Example for ATM simulation: Arrival Time attribute.

State variables:

Is the number of entities in the queue at step  $i$ ,  $NQ_i$ . For example, in an ATM simulation, the ATM status is to indicate whether the ATM is busy or idle at step  $i$ .

Statistical Accumulators: Simple-average: average time customers wait in queue

Time-average: The average number of customers in the queue

Time-average number of customers in the queue:

Simple average time in queue

1. Count the number of customers who pass through the queue
2. As customers move through the queue, waiting times are recorded.
3. Calculated from the time you enter the queue to the time you leave the queue:
4. Calculated from the time you enter the queue to the time you leave the queue: simple-average time in queue =  $t_i - t_{i-1}$

For the duration of the last step ( $t_i - t_{i-1}$ ) and the number of customers who entered the queue during the last step ( $N_{Qi-1}$ ), calculate the Time-Weighted Number of Entities in the Queue =  $(t_i - t_{i-1}) N_{Qi-1}$

Occurrence (Event):

1. Arrival event, occurs when a customer entity arrives in the queue
2. Departure event, occurs when the customer entity completes an ATM transaction
3. Termination event, to end the simulation.

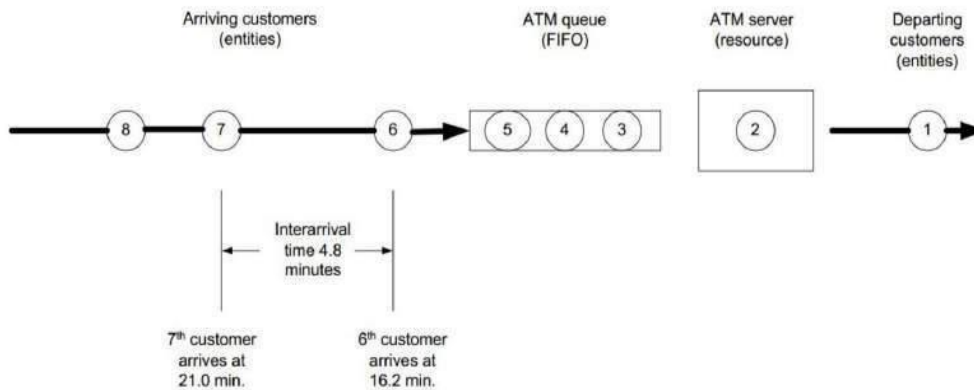

**Figure 10.** Arrival Time Simulation Source: Muhammad Buharudin (2012)

**Hypothesis**

After discussing the background, problem identification, problem formulation and research review, the hypothesis of this research is "The Application of Green Buildings (BGH) Based on Hybrid Dynamics Can Improve Cost Performance in the Application of the BGH Concept for High-Rise Office Buildings".

**State of the Art**

State of the Art is the highest achievement of a development which can be in the form of a device/product, technique/method, or science achieved at a certain time. SOTA can also mean a measure of the level of development (in the form of a device/product, procedure, process, technique/method, or science) achieved at a certain time as a result of applying existing methodologies. In my opinion, SOTA is an important factor for positioning the research to be carried out.

State of the art is the same as Research GAP, grouping journals from both national journals and international journals, the difference is that the state of the art explains more that the research being conducted is the first time it has been conducted and for similar research there are differences in both analytical methods. data, or data processing methods.

**Research Novelty**

Novelty is basically a unit of discovery that is new. Finding new knowledge gaps, new problems and new methods from the many researches that have been released. Research Novelty.

## **RESEARCH METHODS**

### **Research design**

Research methods are the methods used by researchers to obtain data aimed at determining answers to the problems posed. "Research methods are a scientific way to obtain data with specific purposes and uses" (Sugiyono, 2018).

The descriptive method according to (Sari et al., 2022) is "Studies that aim to describe or explain events or happenings that are taking place at the time of the research without paying attention to before and after". The data obtained is then processed, interpreted and concluded. This method is used because the author wants to get a clear picture of the thesis results.

The approach used in this research is a quantitative approach. The quantitative approach is an approach that allows for exact recording and analysis of data from research results and calculating the data using statistical calculations.

This research is intended to obtain an overview of the relationship between students regarding the learning process and real conditions in the Indonesian transportation system.

Data collection techniques were carried out by direct survey or from the literature. The type of data used consists of 3 types, namely:

1. Primary data  
Primary data is data obtained directly through distributing questionnaires to field respondents.
2. Secondary data  
Secondary data is supporting data sourced from literature and existing references. Secondary data is in the questionnaire form regarding obstacles that often occur in the field and how they are handled.
3. Questionnaire Design  
Questionnaires are used as a means of collecting data and as proof of hypotheses. The questionnaire was formed using clear sentences and in accordance with existing concepts, to make it easier for respondents to answer the questions in the questionnaire. Respondents can answer by selecting from the answers provided.

The research begins by knowing the problems that exist in the Residential Building so as to obtain problem identification to create a problem formulation that is appropriate to the research topic and make it into supporting information to facilitate the case objectives. After that, information was collected on determining tools to help in determining hypotheses and determining research objects. Then secondary information is obtained consisting of the RAB of the building project, operational and maintenance costs, information on building materials and materials used, related regulations

Green Building, other data can be used as a reference in analyzing the implementation of cost method integration with System Dynamic and.

### **Object of research**

The research object that will be used as research is the Ginza Business Loft Cikarang Jababeka belonging to Jababeka Residence.



**Figure 11.** Research Object Source: [www.jababekaresidence.com](http://www.jababekaresidence.com) (2022)

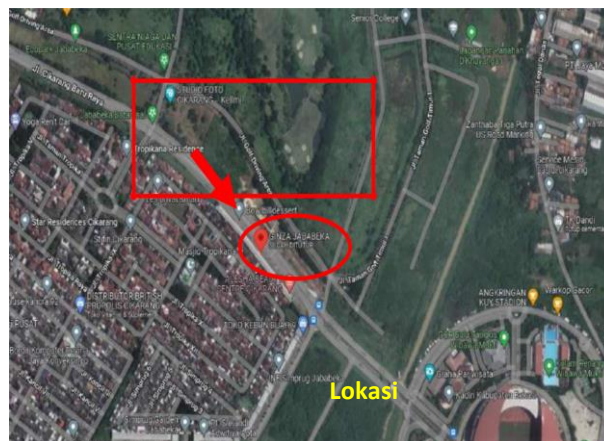

**Figure 12.** Ginza Business Loft Jababeka Location Map Source: [www.googlemaps.com](http://www.googlemaps.com) (2022)

## RESULTS AND DISCUSSION

In this section, we will describe the steps in the research process that have been taken. The explanation includes a series of stages, namely data collection, data validation, data processing, statistical analysis, case studies, and hypothesis testing, as well as the basis for decision making contained in this chapter. When compiling the questionnaire, we tried to find indicators that had a significant impact, by referring to indicators that had been introduced by previous researchers.

The questionnaire that has been prepared will be applied to project stakeholders, involving parties involved directly or indirectly, but has relevance in accordance with previously determined provisions. These stakeholders include various elements in the construction industry, such as academics, consultants, contractors, developers and officials in government agencies.

In carrying out data analysis, researchers used the SMART PLS 3.0 Structural Equation Modeling (SEM) simulation tool. This process will involve interviews to identify the dominant factors and subfactors in influencing cost performance, which is the main focus of this research. SMART PLS is software that is commonly used as a popular analytical tool in the realm of scientific research.

### Influential Factors

This research was conducted with the main aim of identifying the factors that have the most significant impact in implementing the Green Building (BGH) concept in high-rise office buildings based on Hybrid Dynamic, in response to research question (RQ1). By focusing on the answer to RQ1, this research also details efforts to find the factors that have the greatest influence, taking the role as a reference for answering the next research questions, namely RQ2 RQ3. The successful implementation of BGH, in accordance with the Technical Instructions for Green Buildings, PUPR Ministerial Regulation No. 1 of 2022, is an important focus, and therefore, the factors that have the greatest impact are expected to be a guide in indicating their level of importance.

The research process begins with the search for factors and subfactors during data collection, which is carried out using previously designed research instruments. With this approach, the research has a strong basis for exploring the complexity of factors involved in BGH implementation, providing a strong foundation for detailing the findings and supporting the contribution of deeper knowledge about the concept of Green Buildings.

### **Research variable**

This research involves two types of variables, namely independent variables and dependent variables. The independent variable consists of four elements, while the dependent variable consists of one element, as described below: Independent Variables: Offices (X1), Green Buildings (X2), System Dynamics (X3), and Discrete Event Simulation (X4).

### **Main Factor and Sub Factor**

The main factor is an essential component in understanding and analyzing a complex variable. When breaking down the main variables, a subdimensional approach is applied to break them down into more detailed parts. Each main factor in the context of this research is divided into sub-dimensions which function as subcomponents representing specific aspects of the variable. This allows researchers to examine in more detail and depth each element that makes up the main factor, opening up the potential for a more comprehensive understanding of the dynamics and relationships between the elements in the variable. Meanwhile, sub factors are subdivisions of the main factor. Sub Factors consist of specific questions that will be answered and assessed by respondents by giving a value to each question item. Main factors and distribution of sub factors in this research are:

1. Main Factor X1.1: Planning Stage, consisting of 12 sub factors
2. Main Factor X1.2: Implementation Stage, consisting of 9 sub factors
3. Main Factor X1.3: Operation and Maintenance Phase, consisting of 4 sub factors
4. Main Factor X2.1: Planning Stage, consisting of 32 sub factors
5. Main Factor X2.2: Implementation Stage, consisting of 63 sub factors
6. Main Factor X2.3: Utilization Stage, consisting of 58 sub factors
7. Main Factor X2.4: Dismantling Stage, consisting of 9 sub factors
8. Main Factor X3.1: Use of Model, consisting of 7 sub factors
9. Main Factor X3.2: Making Stock Flow Diagrams, consisting of 4 sub factors
10. Main Factor Y1: Internal, consists of 6 sub factors
11. Main Factor Y2: External, consisting of 2 sub factors

### **Preparation of Questionnaires**

The process of preparing this questionnaire was carried out after conducting a literature review and referring to the attachment to the Technical Instructions of Minister of PUPR Regulation No. 1 of 2022. Questionnaire components, such as variables, main factors and subfactors, have been collected in the previous stage. The next step involves combining the results of the literature study into a list of questions to be asked of respondents. These subvariables were then arranged into a research instrument in the form of a questionnaire, which consisted of question items formed by transforming the existing subvariables.

The number of respondents calculated is different from the requirements requested by the SEM-PLS software, namely 163 respondents, this value was obtained from the initial SEM-

PLS modeling. This resulted in additional distribution and collection time for questionnaires in this study. Based on this, the determination of the number of respondents is in accordance with Bagozzi & Yi's statement which suggests having a minimum sample size of 100 so that the results are quite reliable and suggests 200 to be more appropriate because less than 100 will increase the risk of sample abnormalities and the accuracy of the results.

In questionnaires distributed to selected respondents, respondents are expected to provide answers by choosing from a scale of 1-6, which represents various answer criteria. The scale is designed in such a way that a value of 1 reflects the least expected answer, while a value of 6 indicates the most expected answer. The process of assessing research results is involved in developing the level of agreement with statements according to the respondents' views, using a Likert scale according to the value weights listed in the table columns provided. The value weights are explained as follows:

- 1 = Strongly Disagree (STSS)
- 2 = Strongly Disagree (STS)
- 3 = Disagree (TS)
- 4 = Agree (S)
- 5 = Strongly Agree (SS)
- 6 = Strongly Agree (SSS)

PLS (Partial Least Square) is a statistical method that involves three essential stages in the estimation process, in accordance with the description of Lahmoller (1989) and notes of Yamin (2011) as explained in research by Sutikno (2022). These three stages form an important foundation in modeling with PLS, which include:

1. Formation of latent variable scores through weight estimation
2. Calculation of path coefficients, especially those connecting latent variables, as well as estimation of loading factors connecting latent variables with their indicators
3. Estimation of location parameters.

In interpreting the results obtained, several aspects need to be given special attention. This includes consideration of sample size, the presence of missing values, data distribution patterns, and the use of measurement scales. The success of SEM-PLS modeling requires careful evaluation of these aspects, especially in dealing with incomplete observations and selecting the measurement scale for endogenous latent variables so that the model can be identified optimally.

### **SEM-PLS Assessment Criteria**

PLS (Partial Least Square) is a statistical analysis technique that is very suitable, because the focus is on predictions or theory development. If the research objective is more focused on confirmatory modeling and theory testing, then covariance-based CBSEM will be more appropriate. Partial Least Squares (OUTER) is included in the variance-based SEM category, although there are differences with Covariance Based SEM which uses applications such as AMOS (Analysis of Moment Structures) or Lisrel (Linear Structural Relationship) (Sutikno et al., 2022).

The Partial Least Square (PLS) method is an analysis technique that can integrate various approaches, including confirmatory factor analysis, principal component analysis, path analysis, and structural models. Compared to SEM, PLS has a higher level of complexity because it can be applied to both reflective and formative models, while SEM only applies to reflective models.

In PLS, there are three steps in determining latent variables, namely: specifying latent variable relationships based on substantive theory as an inner model; specifying the relationship between latent variables and their indicators or manifest variables (called the measurement model) as an outer model, which is often referred to as an outer relationship that explains how each block of indicators interacts with the latent variables they represent; and estimate the value of latent variables with weighted relationships.



In Smart SEM-PLS, the relationship model is assumed to have latent and indicator variables or manifest variables on a scale of zero means and unit variance (standardized values), so that location parameters (constants) can be removed from the model without affecting the generalization value. PLS does not require parametric techniques to test parameter significance because it does not produce a special distribution for parameter estimation (Sutikno, 2022). The SEM-PLS model assessment criteria are described in the following table.

**SEM-PLS analysis**

The structural model in this research contains 4 main variables which are explained in the following table 2 below.

**Table 2.** Main SEM-PLS Modeling Relationship Path

<b>Manifest Variables/Indicators</b>	<b>Latent Variables</b>	<b>Main Variables</b>
X1.1.1 – X1.1.12	Planning Stage (X1.1)	Office (X1)
X1.2.1 – X1.2.9	Implementation Stage (X1.2)	
X1.3.1 – X1.3.4	Operation and Maintenance Stage (X1.3)	
X2.1.1 – X2.1.32	Planning Stage (X.2.1)	Building Green Building (X2)
X2.2.1 – X2.2.63	Implementation Stage (X2.2)	
X2.3.1 – X2.3.58	Utilization Stage (X2.3)	
X2.4.1 – X2.4.9	Dismantling Stage (X2.4)	
X3.1.1 – X3.1.7	Model Use (X.3.1)	Dynamic System (X3)
X3.2.1 – X3.2.4	Stock low Diagram Creation (X3.2)	
Y1.1 – Y1.6	Internal (Y1.1)	Cost (Y)
Y2.1 – Y2.2	External (Y1.2)	Office

Source: Data processed by researchers, 2023

**Outer Loading Test and Goodness-Fit Model**

Outer Model refers to a measurement model that connects indicators with latent variables, functioning to assess the validity and reliability of the model. The measurement model design (outer model) determines the indicator characteristics for each latent variable, both reflexive and formative, based on the operational definition of the variable. Outer SEM evaluation involves assessing the reflective indicator model, which includes:

1. Individual Item Reliability
2. Construct Reliability or internal consistency
3. Average Variance Extract
4. Discriminant Validity

The first three measurements fall into the convergent validity category. Convergent validity measures the extent of the correlation between constructs and latent variables. In evaluating convergent validity through examining individual item reliability, the standardized loading factor value is an important indicator. Standardized loading factor reflects how strong the correlation is between each measurement item (indicator) and the construct. A loading factor value of  $\geq 0.7$  is considered ideal, indicating that the indicator is valid in measuring the construct it forms. Empirically, a loading factor value of  $\geq 0.5$  is still acceptable, although some experts may tolerate a value of 0.4. Therefore, loading factor values that are  $\leq 0.4$  should be removed from the model. The square of the loading factor value is called communalities, which reflects the percentage of the extent to which the construct can explain the variations contained in the indicators.

The modeling results show that all indicators with an outer loading value  $>0.5$  are declared valid based on the outer loading validity value which states that all indicators have convergent validity as Average Variance Extracted (AVE) as shown in the following table 3 below.

**Table 3.** Cronbach Alpha, Composite Reliability, and Average Variance Extracted

Building Type	Cronbach's Alpha	rhoA	Composite Reliability	Average Variance Extracted (AVE)
Green Building (X2)	0.997	0.997	0.997	0.694
Implementation Stage (X2.2)	0.994	0.994	0.994	0.727
Utilization Stage (X2.3)	0.991	0.991	0.991	0.664
Planning Stage (X2.1)	0.991	0.991	0.991	0,775
Office (X1)	0,977	0.978	0.979	0.651
Hybrid Dynamic (X3)	0.971	0.973	0.975	0.780
System Dynamic (X3.1)	0.963	0.964	0.970	0.820
Planning Stage (X1.1)	0.958	0.960	0.963	0.687
Cost (Y)	0.941	0.947	0.952	0.714
Demolition Stage (X2.4)	0.939	0.943	0.949	0,674
Implementation Stage (X1.2)	0.935	0.938	0.946	0.661
Internal (Y1.1)	0.923	0.931	0.941	0.727
Discrete Event Simulation (X3.2)	0.910	0.917	0.937	0.789
Operation and Maintenance Stage (X1.3)	0.846	0.851	0.898	0.688
Green Building (X2)	0.799	0.822	0.908	0.831

Source: Data processed by researchers, 2023

From the attached table, it can be seen that the Composite Reliability (CR) value for each variable exceeds 0.70. The office variable reaches a CR value of 0.979, green buildings achieve a CR value of 0.997, hybrid dynamic has a CR value of 0.997, and cost performance reaches a CR value of 0.952. The Composite Reliability test results show that all variables show a high level of reliability and have met the minimum value limits that have been set.

Measurements using Cronbach alpha show satisfactory Cronbach Alpha (CA) values for each variable. The office variable has a CA value of 0.977, the green building variable is 0.997, the hybrid dynamic variable is 0.971, and the cost performance variable is 0.941. All CA values are greater than 0.70, indicating that these four variables have a high level of reliability.

Apart from that, the Average Variance Extracted (AVE) value for the cost, office, green building, system dynamic and discrete event simulation performance variables is  $> 0.50$ . This indicates that each variable has good discriminant validity, showing the ability to be clearly distinguished from each other. These results provide confidence that these variables can be considered as distinct concepts and validate the fit between the variables measured in this research model.

The research results show that the Average Variance Extracted (AVE) values for the cost performance variables, offices, green buildings, system dynamics, and discrete event simulation are all greater than 0.50. This shows that each variable has good discriminant validity, showing the ability to be clearly distinguished from each other in the context of this research model. An AVE value that meets or even exceeds the limit value of 0.50 indicates that most of the variance in each variable is explained by the latent construct measured by the indicator.

High discriminant validity is an indicator that the variables studied in this research can be conceptually differentiated from each other clearly and substantially. This means that these variables do not experience significant overlap in their concepts. These results provide confidence that the measurement instruments used in this research can differentiate between variables well and that the conceptually proposed model can provide reliable results. Good discriminant validity is important to ensure that the variables measured truly represent different concepts and that the results of the analysis can be interpreted clearly. With strong discriminant validity, the conclusions or findings drawn from this research become more convincing and can be considered an accurate reflection of the concept being measured.

**Table 4.** R-Square Test (R2)

<b>Building Type</b>	<b>R-square</b>	<b>R-square adjusted</b>
Implementation Stage (X2.2)	0.993	0.993
Planning Stage (X1.1)	0.982	0.982
Internal (Y1.1)	0.982	0.982
System Dynamic (X3.1)	0.980	0.980
Utilization Stage (X2.3)	0.975	0.975
Cost (Y)	0.973	0.973
Implementation Stage (X1.2)	0.973	0.973
Demolition Stage (X2.4)	0.969	0.969
Planning Stage (X2.1)	0.956	0.956
Discrete Event Simulation (X3.2)	0.945	0.944
Green Building (X2)	0.921	0.921
Hybrid Dynamic (X3)	0.915	0.914
Operation and Maintenance Stage (X1.3)	0.875	0.874
External (Y2)	0.869	0.868

Source: Data processed by researchers, 2023

Then, it can be explained that the research results of the R2 value, which is a goodness-fit-model test taken from model data at the outer loading stage and is a value that shows how much the independent (exogenous) variable influences the dependent (endogenous) variable, found that the R2 value has an effect. together the Cost (Y) is 0.973 with an adjusted R2 value of 0.973, thus it can be explained that all independent variables simultaneously influence Cost (Y) by 0.973 or 97.3%. Because Adjusted R2 is 97%  $>$  50%, the influence of all independent variables on Cost (Y) is strong.

The results of this research show that the R2 value, which is used as a goodness-fit-model test and taken from model data at the outer loading stage, provides an idea of how much the independent (exogenous) variable influences the dependent (endogenous) variable, in this case the Hybrid Dynamic (X3). The research results show that the R2 value obtained is 0.915, with an adjusted R2 value of 0.914.

The R2 value which reaches 0.915 indicates that the independent variables together or collectively have an influence of 91.5% on the dependent variable Hybrid Dynamic (X3). This means that most of the variation in the Hybrid Dynamic variable (X3) can be explained by the independent variables measured in this study. Furthermore, the adjusted R2 value which reached 0.914 shows that around 91.4% of the variation in Hybrid Dynamic (X3) can be explained by independent variables after taking into account the number of variables and sample size.

Based on the test results in the table above, it shows that the indicators for each variable in this study have a loading factor value  $> 0.70$ , so they can be declared valid. In discriminant validity testing, the approach commonly used is the Fornell-Larcker Criterion (FLC) and Cross Loadings values, which are indicators of latent constructs which are expected to be greater when compared to cross loadings values on other latent constructs. The following is a table of the results of the Fornel Larcker Criterion (FLC) test in this study as follows:

#### **Inner T-Value and Path Coefficient Analysis**

Based on the results of data processing using the bootstrapping method, the modeled T-statistic value is  $\geq 1.96$ . The relationship between p-value load factor and path coefficient when p-value  $< 0.05$ , then all construct indices are considered valid for use in testing structural measurement hypotheses (Sarstedt et al., 2022).

Based on the table above, it can be seen that X1.1.2 has a P-Values value of 0.000 for X3.1.7 has a P-Values value of 0.000 on

Variable X1.1.2 has a P-Value of 0.000 for variable X1. This shows that the relationship between X1.1.2 and X1 is statistically significant. With a low significance value, it can be concluded that X1.1.2 has a strong influence on variable X1 in the model. Likewise, variable X2.1.17 also has a P-Values value of 0.000 against variable X2, indicating that the relationship between the two is statistically significant. This indicates that X2.1.17 has a significant effect on variable X2. Variable X3.1.7 has a P-Value of 0.000 for variable X3, indicating that the auditor quality variable has a significant effect on variable X3. Furthermore, variable Y1.1 has a P-Values value of 0.000, indicating that this variable has a significant influence on variable Y. These results illustrate that variable Y1.1 has a strong influence on variable Y in the context of the research model. Overall, the results of the P-Values analysis show that the variables mentioned above have a significant influence on the variables measured.

#### **CONCLUSION**

Based on the results of data processing, the R2 value was obtained, namely 0.973 ( $> 0.75$ ), which means that the independent variable (X) studied has a strong relationship with the cost performance variable (Y). There are 10 main factors that have the most significant influence in the context of Structural Equation Modeling Partial Least Squares (SEM-PLS), namely the Implementation Stage (X2.2), Planning Stage (X1.1), Internal Costs (Y1.1), System Dynamics (X3. 1), Utilization Stage (X2.3), Cost (Y), Implementation Stage (X1.2), Demolition Stage (X2.4), Planning Stage (X2.1), Discrete Event Simulation (X3.2). Apart from that, there are also 10 sub factors that have the most significant influence, namely, Electrical energy consumption  $<$  baseline (X2.2.21), Routine library (X3.2.2), Having energy conservation rules (X2.3.6), Initial cost of green ship (X3.1.6) , Main program (X3.2.4), Air conditioning with BMS (X2.1.6), Water saving SOP (X2.2.45), Lighting and air conditioning  $\geq 30\%$  usage (X2.2.24), Environmental costs (Y2.2), Application waste handling system (X2.2.18). Thus, it can be concluded that the application of the green building concept (BGH) in high-rise office buildings based on hybrid dynamic can improve cost performance.

**REFERENCES**

- Anonim. (2020). The benefit of green building for cost efficiency. *International Journal of Financial, Accounting, and Management*, 1(4). <https://doi.org/10.35912/ijfam.v1i4.152>
- Adriyatno, J. (2022). ANALISIS BIAYA PERUBAHAN SPESIFIKASI FASAD GREEN BUILDING DENGAN METODE VALUE ENGINEERING. *NALARs*, 21(1), 57. <https://doi.org/10.24853/nalars.21.1.57-66>
- Aghili, N., & Amirkhani, M. (2021). SEM-PLS Approach to Green Building. *Encyclopedia*, 1(2), 472–481. <https://doi.org/10.3390/encyclopedia1020039>
- Ahmad, P., Misni, A., Kamaruddin, S. M., & Daud, N. (2017). Green Neighbourhood Adaptive Model for Urban Living: A Conceptual Review. *Environment-Behaviour Proceedings Journal*, 2(5), 55. <https://doi.org/10.21834/e-bpj.v2i5.690>
- Bahadure, S., & Kotharkar, R. (2018). Framework for measuring sustainability of neighbourhoods in Nagpur, India. *Building and Environment*, 127, 86–97. <https://doi.org/10.1016/j.buildenv.2017.10.034>
- Bahadure, S., & Kotharkar, R. (2018). Framework for measuring sustainability of neighbourhoods in Nagpur, India. *Building and Environment*, 127, 86–97. <https://doi.org/10.1016/j.buildenv.2017.10.034>
- Elgadi, A. A., Ismail, L. H., Abass, F., & Ali, A. (2016). Developing Urban Environment Indicators for Neighborhood Sustainability Assessment in Tripoli-Libya. *IOP Conference Series: Materials Science and Engineering*, 160, 012046. <https://doi.org/10.1088/1757-899X/160/1/012046>
- Erma Suryani. (2006). *Pemodelan & simulasi / Erma Suryani*. Yogyakarta: Graha Ilmu.
- GBCI. (2015). GREENSHIP RATING TOOLS untuk KAWASAN VERSI 1.0. *Automation in Construction*, 78(62–82).
- Hui, E. C. M., Zhong, J. W., & Yu, K. H. (2012). The impact of landscape views and storey levels on property prices. *Landscape and Urban Planning*, 105(1–2), 86–93. <https://doi.org/10.1016/j.landurbplan.2011.12.002>
- Hussain, T., Abbas, J., Wei, Z., Ahmad, S., Xuehao, B., & Gaoli, Z. (2021). Impact of Urban Village Disamenity on Neighboring Residential Properties: Empirical Evidence from Nanjing through Hedonic Pricing Model Appraisal. *Journal of Urban Planning and Development*, 147(1). [https://doi.org/10.1061/\(ASCE\)UP.1943-5444.0000645](https://doi.org/10.1061/(ASCE)UP.1943-5444.0000645)
- Imron, A. I., & Husin, A. E. (2021). Peningkatan Kinerja Biaya Berbasis Value Engineering Pada Proyek Green Hospital. *Jurnal Aplikasi Teknik Sipil*, 19(3), 323. <https://doi.org/10.12962/j2579-891X.v19i3.9144>
- Islam, M. S., Hossain, R., Morshed, M. M., & Afrin, S. (2020). The value of environmental (dis)amenities in the urban housing market: Evidence from Khulna, Bangladesh. *Journal of Urban Management*. <https://doi.org/10.1016/j.jum.2020.02.001>
- Kineber, A. F., Othman, I., Oke, A. E., Chileshe, N., & Zayed, T. (2021). Exploring the value management critical success factors for sustainable residential building – A structural equation modelling approach. *Journal of Cleaner Production*, 293, 126115. <https://doi.org/10.1016/j.jclepro.2021.126115>
- Latief, Y., Berawi, M. A., Van Basten, Riswanto, & Budiman, R. (2017). Construction Performance Optimization toward Green Building Premium Cost Based on GreenShip Rating Tools Assessment with Value Engineering Method. *Journal of Physics: Conference Series*, 877, 012041. <https://doi.org/10.1088/1742-6596/877/1/012041>

Lin, X., & Wang, P. (2020). Relationship between Rising Housing Prices and Reduction in Urban Agglomeration. *Journal of Urban Planning and Development*, 146(3). [https://doi.org/10.1061/\(ASCE\)UP.1943-5444.0000596](https://doi.org/10.1061/(ASCE)UP.1943-5444.0000596).

Molina, G., Donn, M., Johnstone, M.-L., & MacGregor, C. (2020). Green Labels in Housing: Further Evidence on Their Effectiveness. *Journal of Sustainable Real Estate*, 12(1), 69–83. <https://doi.org/10.1080/19498276.2021.1957417>.

Qu, S., Hu, S., Li, W., Zhang, C., Li, Q., & Wang, H. (2020). Temporal variation in the effects of impact factors on residential land prices. *Applied Geography*, 114, 102124. <https://doi.org/10.1016/j.apgeog.2019.102124>.